

ETAS ES600.2

Synchronization and Power Management Module



User Guide

Copyright

The data in this document may not be altered or amended without special notification from ETAS GmbH. ETAS GmbH undertakes no further obligation in relation to this document. The software described in it can only be used if the customer is in possession of a general license agreement or single license. Using and copying is only allowed in concurrence with the specifications stipulated in the contract.

Under no circumstances may any part of this document be copied, reproduced, transmitted, stored in a retrieval system or translated into another language without the express written permission of ETAS GmbH.

© Copyright 2026 ETAS GmbH, Stuttgart

The names and designations used in this document are trademarks or brands belonging to the respective owners.

ES600.2 | User Guide R10 EN | 06.2026

Contents

1	Introduction	6
1.1	About ES600.2 - Module	6
1.1.1	Scope of application	6
1.1.2	Properties	6
1.2	Target audience and intended use	7
1.3	Safety instructions and classification	8
1.3.1	Classification of Safety Messages	9
1.3.2	Assembly	10
1.3.2.1	Assembly location	10
1.3.2.2	Securing the product	10
1.3.2.3	Ventilation	10
1.3.3	Operation	11
1.3.4	Electrical connection	11
1.3.5	Cables and accessories	12
1.4	Unpacking	12
2	Product overview	14
2.1	Graphical overview of elements	14
2.1.1	Front side	14
2.1.2	Rear side	14
2.2	Compatibility	15
2.2.1	System requirements	15
2.2.2	Compatible products	15
3	Hardware setup	16
3.1	Transportation and packaging	16
3.2	Mounting and placement	16
3.2.1	Fastening the module on a carrier system	16
3.2.2	Mechanically connecting several modules	17
3.3	Connection to the power supply	19
3.4	Connection with other products	19
4	Basic operation	21
4.1	Status indicator	21
5	Overview of functions	25
5.1	Operating modes	25
5.2	Ethernet switch	25

5.2.1	"FE-HOST" host connection	25
5.2.2	"GE-HOST" host connection	25
5.2.3	Ethernet connections "ETH1" to "ETH6"	26
5.2.3.1	Power supply of connected modules	26
5.3	Time synchronization	26
5.4	"Wake-Up" function	27
6	Commissioning	28
6.1	Prerequisite for successful initialization of the module	28
7	Use cases	29
7.1	Putting a simple module compound in operation	29
7.2	Putting a complex module compound in operation	29
8	Technical specification	31
8.1	Hardware specifications	31
8.1.1	Ambient conditions	31
8.1.2	Electrical data	31
8.1.3	Mechanical data	32
8.2	Interface specifications	32
8.2.1	"GE-Host" connection	32
8.2.2	"FE-HOST" connection	32
8.2.3	Ethernet connections "ETH1" to "ETH6"	33
8.3	Product markings	33
8.4	Connectors	35
8.4.1	Terminal assignment of sockets	35
9	Maintenance	39
9.1	Cleaning	39
9.2	Firmware and software update	39
9.2.1	Updating the Firmware	39
9.3	Repair service	39
10	Return form	40
11	Accessories and order information	41
11.1	Module	41
11.2	Cables	41
11.2.1	Power cables	41
11.2.1.1	CBP120-2	41
11.2.1.2	CBP1205	42

11.2.2	Data cables	42
11.2.2.1	CBE100-3 / CBE100-8	42
11.2.2.2	CBE130-0m45 / CBE130-3	43
11.2.2.3	CBE140-0m45	43
11.2.2.4	CBE250-3 / CBE250-5 / CBE250-8	43
11.2.3	Adapter cables	44
11.2.3.1	CBAE330-0m5	44
11.3	Other	44
11.3.1	Housing accessories	44
12	Contact information	45
13	Legal information	46
13.1	Use of Open Source Software	46
13.2	Certification and conformity	46
13.2.1	Declarable substances	46
13.3	Standards and norms	46
13.3.1	EMC Class B	47

1 Introduction

1.1 About ES600.2 - Module

The ES600.2 Synchronization and Power Management Module is an Ethernet switch with integrated voltage supply and time synchronization for connecting several data acquisition or interface modules to a host PC.

The module is equipped with two upstream Ethernet connections for data exchange with the host PC or a drive recorder and six downstream Ethernet connections for connecting ETAS modules and compatible Ethernet-enabled devices.

The ES600.2 can be cascaded so that larger module compounds can be built.



1.1.1 Scope of application

The ES600.2 can be used for the following tasks:

- Connecting several data acquisition or interface modules to a host PC via Ethernet
- Supplying connected ES4xx and ES6xx modules with power via the Ethernet connection cable
- Synchronizing connected ETAS modules and their measuring channels
- Connecting ECUs that are equipped with an XETK or a separate Ethernet interface
- Building larger cascaded module compounds with additional ES600.2 modules

1.1.2 Properties

The most important properties at a glance:

- Ethernet switch with 10/100/1000 Mbit/s data rate
- One upstream Gigabit Ethernet host connection (GE-host)
- One upstream Fast Ethernet host connection (FE-host)
- Six downstream Fast Ethernet connections for compatible modules (ETH1 to ETH6)
- Status indicator for every connection
- Sequential switch-on of connected modules to avoid high start-up peaks
- Automatic standby function for connected modules
- Precise synchronization of all connected modules and their measuring channels
- Automotive-capable module for use in the development environment and in the vehicle on test courses
- Wide supply voltage range
- High level of mechanical stability and robustness

1.2 Target audience and intended use

Target audience

For the safe and efficient use of the product, the user is expected to have comprehensive expertise and practical experience in the following automotive domains:

- Electrical and electronic system architectures in motor vehicles
- Sensor technology and control engineering
- Bus systems and communication protocols
- Electronic control unit (ECU) development and calibration
- Safety guidelines and regulatory requirements for the development and validation of vehicle systems

Intended use

The product was developed and approved for applications in the automotive sector. Only operate the product as per its specifications. If the product is used in any other way, product safety is no longer ensured.

The interface modules are designed for the following applications:

- Detecting signals from ETK and ECU interfaces, as well as from vehicle buses
- Flash programming of ECUs

Application areas

- The product is approved for use in the following areas:
 - Interior
 - Passenger compartment
 - Trunk
- Do not operate the product in a wet or damp environment.
- Do not operate the product in potentially explosive atmospheres.

Technical condition

The product is designed in accordance with state-of-the-art technology. Only operate the product and its accessories if they are in perfect working order. Shut down a damaged product immediately. Do not open or alter the product. Only ETAS may make changes to the product.

1.3 Safety instructions and classification

Refer to the following safety instructions and the technical documentation available to download from the ETAS website www.etas.com. Keep the information provided in a safe place.

Failure to comply with the safety instructions may lead to the risk of damage to life and limb or property. The ETAS Group and its representatives shall not be liable for any damage or injury caused by improper operation or use of the product.

Only use the product if you have read and understood the information concerning safe operation and have the required qualifications and training for this product. If you have questions about safe operation, contact ETAS:

- Technical Support: www.etas.com/hotlines
- Regional ETAS Contact Partner: www.etas.com/contact

The product is only approved for the applications described in the technical documentation. When using and operating this product, all applicable regulations and laws must be observed.

ETAS products, made available as beta versions or prototypes of firmware, hardware and/or software, are to be used exclusively for testing and evaluation purposes. These products may not have sufficient technical documentation and not fulfill all requirements regarding quality and accuracy for market-released series products. The product performance may therefore differ from the product description. Only use the product under controlled testing and evaluation conditions. Do not use data and results from beta versions without prior and separate verification and validation and do not share them with third parties.

Before commissioning, check whether a Known Issue Report (KIR) is available for the current product version: www.etas.com/kir (Password: KETASIR). Note the information given in the report.

Program codes or program control sequences that are created or changed via ETAS products, as well as all types of data obtained through the use of ETAS products, must be checked for their reliability and suitability prior to use or distribution. Only use these codes or sequences in public areas (e.g. in road traffic) if you have ensured that the application and product settings are safe through testing in self-contained and designated testing environments and circuits.

This ETAS product allows you to influence safety-relevant systems or data (e.g. in motor vehicles, vehicle components and test benches). In the event of a malfunction or a hazardous situation, it must be possible to put the system into a safe state (e.g. emergency stop or emergency operation).

1.3.1 Classification of Safety Messages

Safety messages warn of dangers that can lead to personal injury or damage to property:



DANGER

DANGER indicates a hazardous situation that, if not avoided, will result in death or serious injury.



WARNING

WARNING indicates a hazardous situation that, if not avoided, could result in death or serious injury.



CAUTION

CAUTION indicates a hazardous situation that, if not avoided, could result in minor or moderate injury.

NOTICE

NOTICE indicates a situation that, if not avoided, could result in damage to physical property.

ATTENTION

ATTENTION indicates a situation that, if not avoided, could result in damage to digital property like data loss, data corruption and system vulnerability.

1.3.2 Assembly

Only install, connect, disconnect and cable ETAS products and components when they are de-energized.

Only screw the product onto the carrier system using M3 cylinder screws and a max. torque of 0.8 Nm. The screw-in depth in the blind hole of the housing measures max. 3 mm.

1.3.2.1 Assembly location**NOTICE****Damage to the electronics due to potential equalization**

The cables' shield may be connected to the housing, the ground or the ground for the product's power supply. If there are different ground potentials in the test setup, equalizing currents can flow between the products via the cables' shield.

Take account of different electric potentials in your test setup and take appropriate measures to prevent equalizing currents.

1.3.2.2 Securing the product

The housing must not be damaged while securing the product.

**WARNING****Risk of injury due to inadequate fastening**

- Secure the product so that it does not move uncontrollably.
- Only use carrier systems and fastening materials that can accommodate the static and dynamic forces of the product and are suitable for the ambient conditions.

1.3.2.3 Ventilation

- Protect the product against direct solar radiation and other sources of heat.
- Ensure that there is sufficient air circulation for efficient heat exchange.

1.3.3 Operation

Only operate the product with the latest firmware. You can find information about updating the firmware in the chapter "[Firmware and software update](#)".

If the firmware update is not completed successfully, try it again. If a new firmware update is not possible and the product is not functional, send the product to ETAS.



WARNING

Risk due to undefined vehicle behavior during an ECU reset

If you operate the product in combination with ETKs, the ECU must not be reset in an uncontrolled manner.

- Only make changes when the vehicle is stationary (e.g. changes to the test setup, changes to the ETK configuration, software updates).

1.3.4 Electrical connection



WARNING

Risk to life from electric shock

If an unsuitable power supply is used, this may generate a hazardous electrical voltage.

- Use a power supply that is permitted for the product.
- Do not connect the product to power outlets.
- To prevent inadvertent connection to power outlets, use power cords with safety banana plugs in areas with power outlets.

Electrical safety and power supply

- Only connect the product to electric circuits with safety extra-low voltage in accordance with IEC 61140 (devices of class III) within the voltage limits for accessible parts as per IEC 61010-1.
- Observe the connection and setting values.
- The power supply for the product must be safely disconnected from the supply voltage. For example, use a car battery or a suitable lab power supply.
- Only use lab power supplies with dual protection for the supply network (with double/reinforced insulation (DI/RI)).
- The power supply must be suitable for use according to the ambient conditions for the product.

- It is possible to discharge the vehicle battery in regular operation and long standby operation.
- Central load-dump protection is required for operation.

Connection to the power supply

The product is powered by an external power supply.

- Only connect the product to the power supply via a suitable fuse protection.
- Ensure that the connections of the power supply are easily accessible.

1.3.5 Cables and accessories

Cables

- Only use ETAS cables, cables recommended by ETAS or other cables certified for the application.
- Route the cables such that they are protected against abrasion, damage, deformation and kinking.
- Do not place any objects on the cables.
- Do not use any damaged cables.
- The connector and connection must not be dirty.
- The connector and connection must be compatible.
- Correctly align the connector with the connection.
- Do not connect the connector and connection by force.

Accessories

Use ETAS accessories, accessories recommended by ETAS or other accessories certified for the application.

1.4 Unpacking

1. Prepare workspace

Unpack in a clean, dry, well-lit area with enough space for the equipment and avoid static damage or physical harm.
2. Open package

Use appropriate tools to carefully open the box without damaging the contents.
3. Verify contents

Compare the items with the packing list "Contents of Package" to ensure all components are present.

4. Inspect for damage

Visually check each item for physical damage. If found, document and report it on www.etas.com/hotlines.

2 Product overview

2.1 Graphical overview of elements

2.1.1 Front side

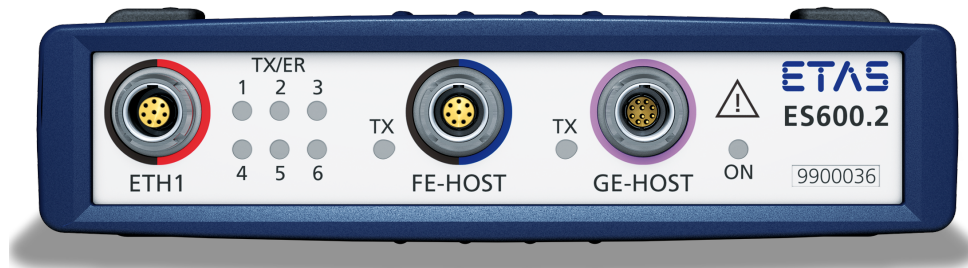

Fig.	Connection	Description
ETH1	LEMO 1B	Fast Ethernet downstream connection with integrated power supply and SYNC-OUT
FE-HOST	LEMO 1B	Fast Ethernet upstream host connection with SYNC-IN
GE-HOST	LEMO 1B	Gigabit Ethernet upstream host connection

2.1.2 Rear side



Fig.	Connection	Description
7-29 V DC	Power supply	Operating voltage connection
ETH2 - ETH6	LEMO 1B	Fast Ethernet downstream connection with integrated power supply and SYNC-OUT

2.2 Compatibility

2.2.1 System requirements

For the configuration of the product as well as the control and data acquisition, you need ETAS software in the following versions:

INCA	starting with Version 7.1.9
HSP	starting with Version 10.9.0

2.2.2 Compatible products

The ES600.2 supports direct connection to the following ETAS modules and systems:

Gigabit Ethernet (GE) host side:

- PC
- ES8xx

Fast Ethernet (FE) host side:

- PC
- ES592
- ES595
- ES600.2
- ES8xx
- ES910.3

Fast Ethernet (FE) module side:

- ES4xx
- ES592
- ES595
- ES6xx
- ES910.3
- ES930.1
- XETK

3 Hardware setup

3.1 Transportation and packaging

Transport

- Only transport the product individually.
- Remove all connected cables before transportation.
- Do not transport the product by the connected cables.

3.2 Mounting and placement



WARNING

Risk of injury due to inadequate fastening

- Secure the product so that it does not move uncontrollably.
- Only use carrier systems and fastening materials that can accommodate the static and dynamic forces of the product and are suitable for the ambient conditions.

3.2.1 Fastening the module on a carrier system

The ES600.2 has a robust metal housing that is fitted with non-slip plastic feet. The module can be screwed onto a carrier system for fastening in a vehicle or lab. The screw threads for fixing the module are part of the housing and are easily accessible.

To fix the housing of the ES600.2, proceed as follows:

1. Remove the plastic feet at the underside of the module. To do so, push a blunt screwdriver between the housing bottom and the plastic foot.
2. Pry off the plastic foot.

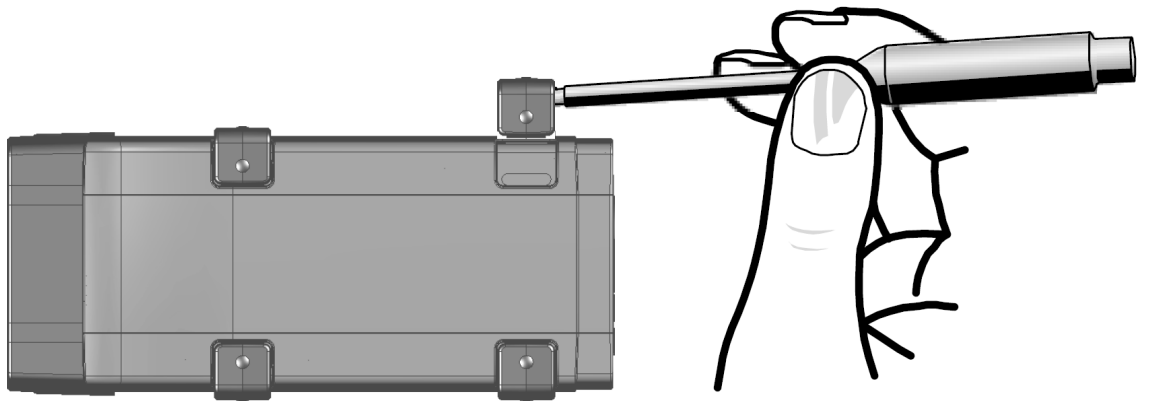

Fig. 3-1: Fig. 4-1 Prying off the plastic foot

A screw thread becomes visible under the plastic foot. The threads for fixing the module are located at the underside of the housing.

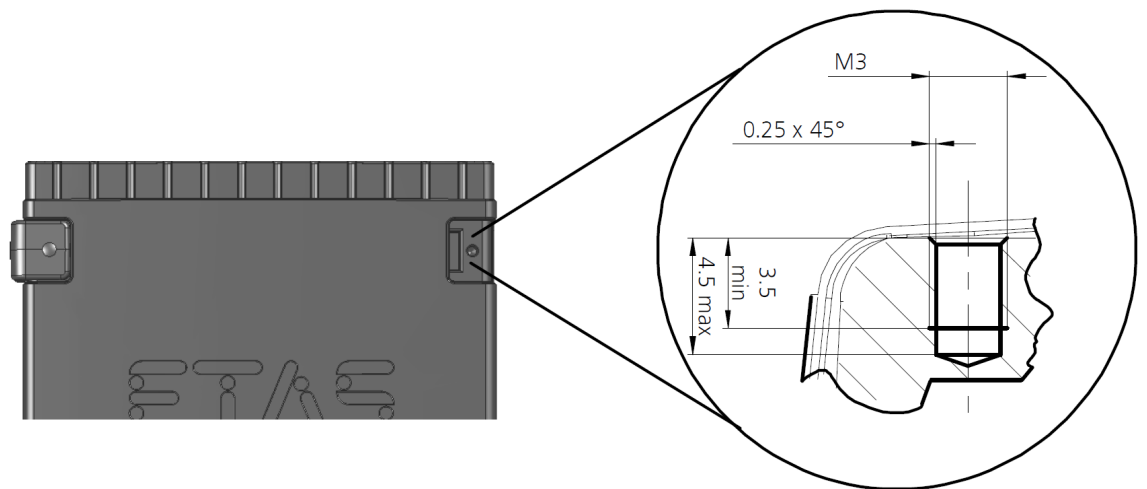

Fig. 3-2: Fig. 4-2 Blind hole with thread

Note

Screw the module onto your carrier system using exclusively M3 cylinder screws and a max. torque of 0.8 Nm.

The screw-in depth in the blind hole of the housing measures max. 3 mm.

3.2.2 Mechanically connecting several modules

Because of the use of ETAS system housings, the Synchronization and Power Management Module can also be connected with modules of the ETAS compact series, for example ES59x, ES6xx and ES910. They can be combined into larger blocks using the supplied T-connectors.

Underneath the ES600.2, you can attach an additional module of the ETAS compact series. To do so, remove the four plastic feet at the corresponding side of the device and install the supplied T-connectors in their place.

To mechanically connect several modules, proceed as follows:

1. Remove the four plastic feet at the underside of the ES600.2 to be able to fasten an additional module.
2. Remove the four plastic feet on the corresponding side of the second module.
3. Turn the locks of the T-connectors crosswise to the longitudinal axis of the connectors.
4. Click two connectors into the installation openings at one longitudinal side of the first module.
5. Click the second module into the two T-connectors.
6. Turn the locks of the T-connectors a quarter turn. This locks the connection of the two modules.
7. Click the two other T-connectors into the installation openings at the opposite longitudinal side of the device.
8. Lock these connectors, too.
9. To stack additional modules and fasten them above each other, repeat the process with the next module.

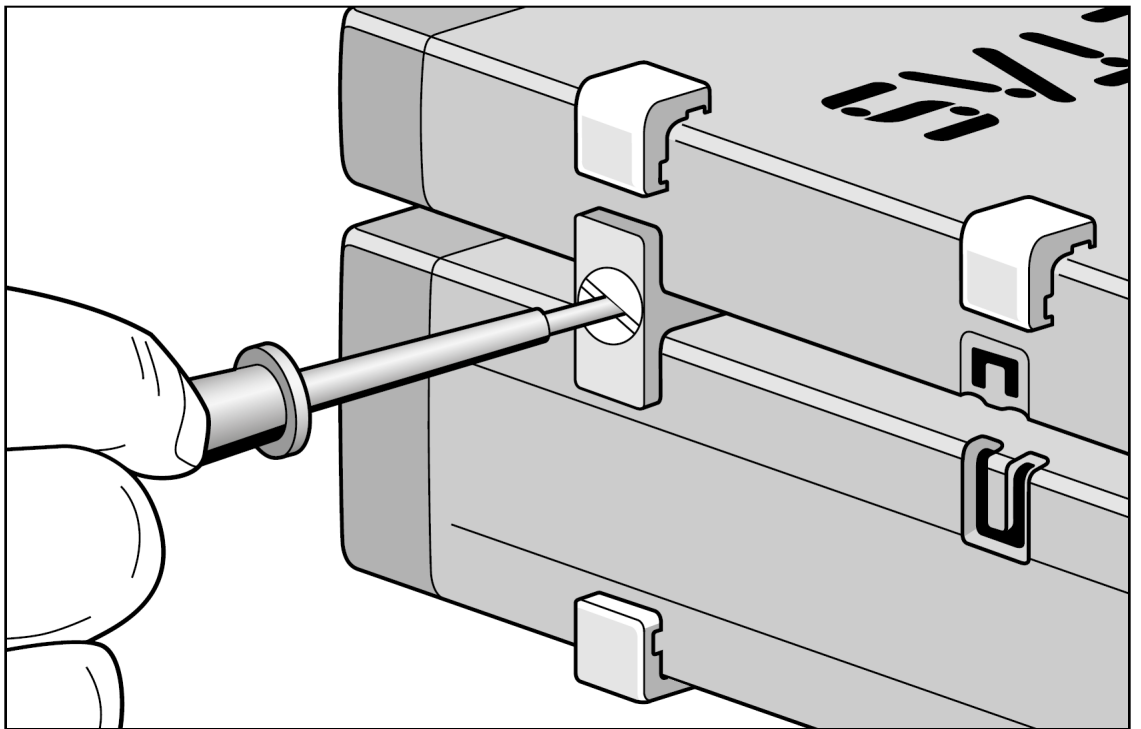

Fig. 3-3: Fig. 4-3 Connecting the ES600.2 with another module

3.3 Connection to the power supply



WARNING

Risk to life from electric shock

If an unsuitable power supply is used, this may generate a hazardous electrical voltage.

- Use a power supply that is permitted for the product.
- Do not connect the product to power outlets.
- To prevent inadvertent connection to power outlets, use power cords with safety banana plugs in areas with power outlets.

The ES600.2 is powered by an external power supply.

3.4 Connection with other products

NOTICE

Damage to the electronics due to potential equalization

The cables' shield may be connected to the housing, the ground or the ground for the product's power supply. If there are different ground potentials in the test setup, equalizing currents can flow between the products via the cables' shield.

Take account of different electric potentials in your test setup and take appropriate measures to prevent equalizing currents.



Note

Ensure that the test setup is EMC-compliant. A test setup that uses shielded and unshielded components at the same time can lead to impairment of the signal quality and is not recommended by ETAS.



Note

Please ensure that the device is installed and operated as described in the user manual to maintain the specified EMC properties in the respective application. Deviation from the specified installation and operation instructions or connecting the device with other devices may result in a deviation from the specified EMC properties.

The ES600.2 is designed to connect to measurement modules, a Gigabit Ethernet host, a Fast Ethernet host and an external power supply.

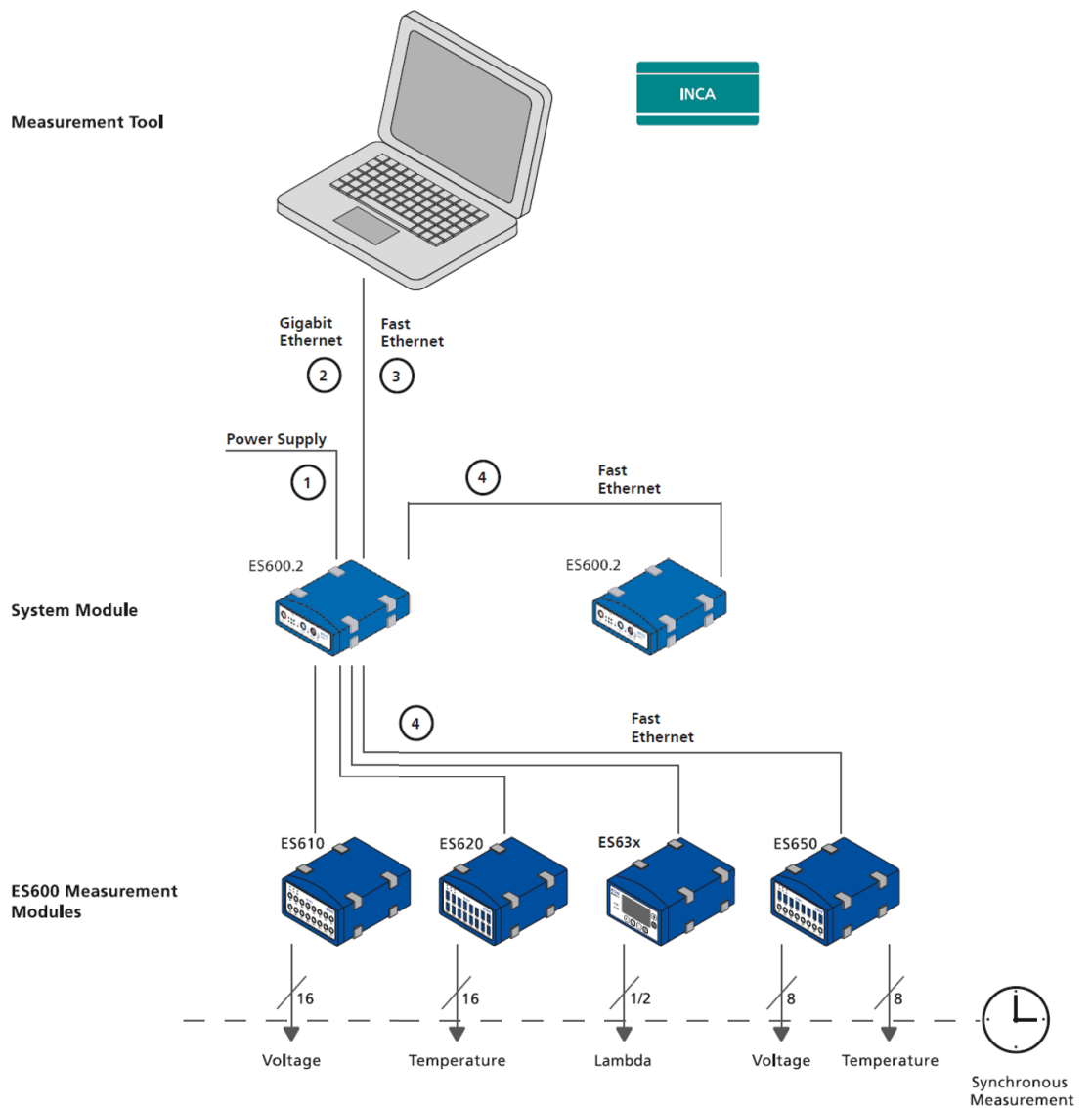

Fig.	Function	Short name
1	Connection to power supply	CBP120 CBP1205
2	Connection to Gigabit Ethernet host	CBE250
3	Connection to Fast Ethernet host	CBE100
4	Connection to Ethernet interface ETH1 -6	CBE130 CBE140

4 Basic operation

4.1 Status indicator



The ES600.2 is equipped with LEDs for displaying the module's operating state, as well as for displaying the function of the Automotive Ethernet interfaces.





Note

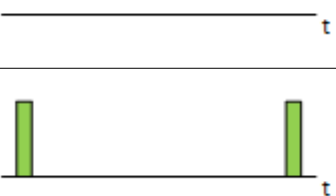

When the ES600.2 is switched on, all LEDs light up briefly.

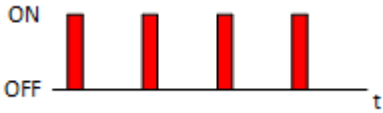
ON



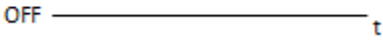

LED code	Display	State
ON OFF	Off	No power supply
ON OFF		Flashing green Module in operating mode "Standby", minimum current consumption. Changing to the "Normal" state requires a Wake-Up event
ON OFF		Lit green Module in operating mode "Normal"
ON OFF		Flashing green Module is synchronization master, module is not externally synchronized

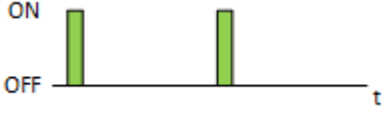
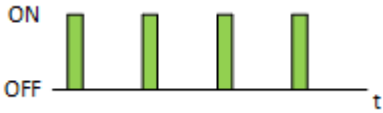
LED code	Display	State
	Flashing green	Module is synchronization slave, module is externally synchronized: at FE-HOST connection
	Flashing red	Firmware update is being performed
	Lit red	Error



TX (FE-HOST)

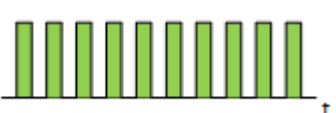

LED code	Display	State
	Off	No Ethernet connection
	Green	Ethernet connection (upstream) active
	Flashing green (3 times per second)	Data transfer with 10 Mbit/s
	Flashing green (6 times per second)	Data transfer with 100 Mbit/s

TX (GE-HOST)

LED code	Display	State
ON OFF 	Off	No Ethernet connection
ON  OFF	Green	Ethernet connection (upstream) active
ON  OFF	Flashing green (3 times per second)	Data transfer with 10 Mbit/s
ON  OFF	Flashing green (6 times per second)	Data transfer with 100 Mbit/s
ON  OFF	Flashing green (12 times per second)	Data transfer with 1000 Mbit/s

TX/ER1 - 6 (ETH)

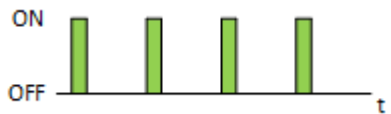
LED code	Display	State
ON OFF 	Off	No Ethernet connection
ON  OFF	Green	Ethernet connection (downstream) active
ON  OFF	Flashing green (3 times per second)	Data transfer with 10 Mbit/s

LED code	Display	State
	Flashing green (6 times per second)	Data transfer with 100 Mbit/s
	Lit red	Current overload by the connected module

5 Overview of functions

5.1 Operating modes

The Automotive Ethernet interfaces can be configured in the following operating modes:

- Communication with BR_XETK
- Ethernet Monitoring and active protocol communication

5.2 Ethernet switch

The integrated Ethernet switch is used for connecting the ES600.2 module and additional measuring or interface modules to a user PC. The data acquisition of the connected modules is done synchronized ([Time synchronization](#)). The Ethernet switch can be cascaded with additional network modules so that you can also build larger blocks of measuring and interface modules.

The switch is equipped with a host connection (Fast Ethernet), a host connection (Gigabit Ethernet) and six Ethernet connections (10/100BaseT Ethernet).

All connections of the switch, except for the Ethernet connections "ETH1" to "ETH6", are electrically isolated from each other and from the power supply.

5.2.1 "FE-HOST" host connection

The upstream "FE-HOST" Ethernet interface connects the ES600.2 module with the user PC or the downstream Ethernet interface of another module. This interface enables the ETAS software tools to access the connected modules.

"Wake-Up" function

The "FE-HOST" Ethernet interface supports the ["Wake-Up" function](#).

Compatible modules

A list of the compatible modules is located in ["Compatible products"](#).

5.2.2 "GE-HOST" host connection

The upstream "GE-HOST" Ethernet interface connects the ES600.2 module with the user PC or the downstream Ethernet interface of another module. This interface enables the ETAS software tools to access the connected modules.

"Wake-Up" function

The "GE-HOST" Ethernet interface supports the ["Wake-Up" function](#).

Compatible modules

A list of the compatible modules is located in [Compatible products](#)".

5.2.3 Ethernet connections "ETH1" to "ETH6"

The ES600.2 module provides six downstream Ethernet interfaces for additional modules. The Ethernet interfaces "ETH1" to "ETH6" are based on the 10/100BaseT standard and can be operated with 10 Mbit/s or 100 Mbit/s, half duplex or full duplex. The switchover is done automatically to the highest possible connection speed.

ECUs that are equipped with an XETK or feature a separate Ethernet interface can be connected directly to the module and communicate with the application software via XCP-on-Ethernet.

Module compound

The connections "ETH1" to "ETH6" connect the ES600.2 module with additional ES600 modules, measuring modules, calibration modules and rapid prototyping modules. The cascability also allows implementing larger blocks of measuring and interface modules.

5.2.3.1 Power supply of connected modules

The ES600.2 can also take on the power supply of connected ES4xx modules and ES6xx modules via the Ethernet connecting cable. Observe the maximum output current at the Ethernet interfaces when cascading the modules.

Other modules connected via Ethernet cable must be cabled separately with the power supply.

"Wake-Up" function

The Ethernet interfaces "ETH1" to "ETH6" support the ["Wake-Up" function](#).

Compatible modules

A list of the compatible modules is located in ["Compatible products](#).

5.3 Time synchronization

To synchronize the measuring channels in a module compound, the modules of the system provide a global time clock.

Modules connected to the "FE-HOST" interface can synchronize the ES600.2 (SYNC-IN). If no synchronization signal is received at the "FE-HOST" connection, the ES600.2 automatically takes over the function of the master module for the synchronization.

The time synchronization unit of the ES600.2 master synchronizes the connected modules via Ethernet lines. At the connections "ETH1" to "ETH6", the synchronization signal is passed on to connected modules (SYNC-OUT). The slave modules adjust to the cycle specified by the master module.

A phase shift of the individual measuring signals to each other is ruled out, even if the measured values are acquired from different modules.

The data of all connected modules of the series ES4xx, ES51x, ES6xx and the XETK are acquired synchronously (ETAS device synchronization).

The ES600.2 provides a fail-safe bypass function for the Automotive Ethernet interfaces AE1 to AE4. Two integrated relays ensure that communication between connected nodes is maintained even when the device is powered off. Due to fast relay switching and link re-establishment, ongoing communication is typically not interrupted. The actual behavior depends on the link recovery characteristics of the connected nodes.

Relay mode also allows decoupling of the measurement hardware from the system under test without rewiring. This enables temporary exclusion of any influence of the measurement setup on the communication between the ECUs.

5.4 "Wake-Up" function

If the system is used in a vehicle, the energy consumption must be as low as possible since the measuring setup is supplied by a battery. For this reason, the ES600.2 module is equipped with a link signal detector at all connections for automatic power-save function.

With the "Wake-Up" function, the module can automatically switch between the operating states "Standby" and "On".

The ES600.2 and modules connected to it automatically switch to the "Standby" operating state if no connection receives any link signals any longer or the host computer is switched off or disconnected. As soon as at least one of these connections receives link signals or the host computer is activated again, the module automatically changes to the "On" operating state ("Wake-Up" function) and automatically switches on all ETAS modules connected in the measuring system.

Note

The automatic switch-on of the ES600.2 via the "Wake-Up" function is possible at all Ethernet connections.

Note

For a connected PC to send link pulses, its Ethernet adapter must be configured accordingly.

6 Commissioning

6.1 Prerequisite for successful initialization of the module

 **Note**

When connecting the ES600.2 with operating voltage and an active Ethernet connection to HOST, the module boots. If the Ethernet connection does not exist, the module changes to the "Standby" operating state.

 **Note**

Disable the automatic power-saving function of the PC network adapter to prevent the adapter from switching to power-save mode when there is no data traffic at the Ethernet interface.

7 Use cases

7.1 Putting a simple module compound in operation

To put a simple module compound in operation, the cables CBE100 or CBE250, CBE130 or CBE140 and CBP120 or CBP1205 are required.

Connecting with the PC:

1. Connect the PC and the FE-HOST connection of the ES600.2 module placed highest in the hierarchy with the cable CBE100. Connect the RJ-45 plug connector with the open Ethernet interface of your PC.

or

2. Connect the PC and the GE-HOST connection of the ES600.2 module placed highest in the hierarchy with the cable CBE250. Connect the RJ-45 plug connector with the open Ethernet interface of your PC.

Connecting with the measuring modules:

1. Connect the HOST connections of your data acquisition and interface modules from the ES6xx series with one unused connection ETH1 to ETH6 each of the ES600.2. Use a cable of type CBE130 or CBE140 for this purpose. Insert the ends marked in blue into the HOST connections of the data acquisition and interface modules and the ends marked in red into the connections ETH1 to ETH6 of the ES600.2.

Connecting with the sensors:

1. Connect the sensors with the inputs of the data acquisition modules. Relevant notes are in the User's Guides of the individual modules.

Connecting with the power supply:

1. Connect the cable CBP120 or the cable CBP1205 for the power supply with the connections 7-29 V of the ES600.2 and with the desired power supply. In the process, observe the current consumption of the ES600.2, the data acquisition and interface modules connected to it and their supply voltage range. The permissible values are listed in the section "Technical Data" on page 26 and in the User's Guides of the individual modules.

Starting the application program:

1. Start INCA. The information for the configuration and measured value acquisition is located in the INCA online help.

7.2 Putting a complex module compound in operation

For larger module compounds, it is meaningful to create a drawing of the planned compound. Figure Fig. 4-4 on page 22 shows an example for a module compound with two cascaded ES600.2 modules and additional ES6xx measuring modules.

To put a complex module compound in operation, the cables CBE100 or CBE250, CBE130 or CBE140 and CBP120 or CBP1205 are required.

Connecting with the PC:

1. Connect the PC and the FE-HOST connection of the ES600.2 module placed highest in the hierarchy with the cable CBE100. Connect the RJ-45 plug connector with the open Ethernet interface of your PC.

or

2. Connect the PC and the GE-HOST connection of the ES600.2 module placed highest in the hierarchy with the cable CBE250. Connect the RJ-45 plug connector with the open Ethernet interface of your PC.

Connecting with additional ES600.2 modules:

1. To cascade the ES600.2, connect the FE-HOST connection of the lower-level ES600.2 with one of the connections ETH1 to ETH6 of the higher-level ES600.2. Use a cable of type CBE130 or CBE140 for this purpose. In the hierarchy, the higher-level ES600.2 is located closer to the host PC.

Connecting with the measuring modules:

1. Connect the HOST connections of your data acquisition and interface modules from the ES6xx series with one unused connection ETH1 to ETH6 of the ES600.2. Use a cable of type CBE130 or CBE140 for this purpose. Insert the ends marked in blue into the HOST connections of the data acquisition and interface modules and the ends marked in red into the connections ETH1 to ETH6 of the ES600.2.

Connecting with the sensors:

1. Connect the sensors with the inputs of the data acquisition modules. Relevant notes are in the User's Guides of the individual modules.

Connecting with the power supply:

1. Connect the cable CBP120 or the cable CBP1205 for the power supply with the connections 7-29 V of the ES600.2 and with the desired power supply. In the process, observe the current consumption of the ES600.2, the data acquisition and interface modules connected to it and their supply voltage range. The permissible values are listed in the section "Technical Data" on page 26 and in the User's Guides of the individual modules.

Starting the application program:

1. Start INCA. The information for the configuration and measured value acquisition is located in the INCA online help.

8 Technical specification

8.1 Hardware specifications

8.1.1 Ambient conditions

Operating temperature range	-40°C to +70°C -40°F to +158°F
Storage temperature range (without packaging)	-40°C to +85°C -40°F to +185°F
Max. relative humidity (non-condensing)	85% (operation) 95% (storage)
Max. altitude	5000 m / 16400 ft.
Degree of contamination (IEC 60664-1, IEC 61010-1)	2
Protection rating (IEC 60529) (when closed)	IP40

8.1.2 Electrical data

Operating voltage range	7 V to 29 V DC
Max. current consumption	14 A
Typical current consumption (operation) ¹⁾	approx. 210 mA (at 14.4 V DC)
Typical current consumption (standby) ¹⁾	approx. 60 mA (at 14.4 V DC)
Maximum voltage to ground or to all accessible parts (e.g. ECU housing, vehicle chassis)	50 V DC / 30 V AC
Overvoltage category (mains supply, IEC 60664-1)	II
Power supply of connected modules	Each "ETH" connection: nom. max. 2 A

Energy management	On/Off with Start/Stop of Ethernet data transfer (On/Off upstream module)
Protection	Reverse polarity-protected and load dump protection in accordance with ISO 16750-2 Test B (central load dump protection required)
1) without power supply of connected modules	

8.1.3 Mechanical data

Dimensions (H x W x D)	36 x 127 x 160 mm 1.42 x 5.00 x 6.30 in
Weight	0.64 kg / 1.42 lb

8.2 Interface specifications

8.2.1 "GE-Host" connection

Connection type	Upstream
Number	1 (GE-HOST)
Connection	10Base-T/100Base-TX/1000Base-T Ethernet
Synchronization	IEEE1588-2008 synchronization



8.2.2 "FE-HOST" connection



Connection type	Upstream
Number	1 (FE-HOST)
Connection	10Base-T/100Base-TX Ethernet
Synchronization	ETAS synchronization mechanism IEEE1588-2008: no synchronization, no forwarding of synchronization signals
Synchronization resolution	1µs

8.2.3 Ethernet connections "ETH1" to "ETH6"

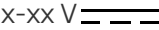
Connection type	Downstream
Number	6 (ETH1, ETH2, ETH3, ETH4, ETH5, ETH6)
Connection	10Base-T/100Base-TX Ethernet
Synchronization	ETAS synchronization mechanism IEEE1588-2008: no synchronization, no forwarding of synchronization signals
Synchronization resolution	1µs
Nom. max. output current for each "ETH" connection	2 A
Power supply of connected modules	ES4xx and ES6xx measuring modules

8.3 Product markings

Symbol	Description
	Please read the user manual before starting up the product.
SN: xxxxxxxx	Serial number
F 00K xxxxxxxx	Order number
x-xx V 	Operating voltage range DC
xxx mA	Max. current consumption
	<p>China RoHS</p> <p>With the China RoHS identification attached to the product or its packaging, ETAS confirms that the product meets the guidelines of the "China RoHS" (Management Methods for Controlling Pollution Caused by Electronic Information Products Regulation) applicable in the People's Republic of China.</p>

Symbol	Description
	<p>CE conformity</p> <p>With the CE mark attached to the product or its packaging, ETAS confirms that the product corresponds to the applicable, product-specific Directives of the European Union.</p> <p>The EU Declaration of Conformity for the product is available upon request.</p> <p>European Union</p> <p>The EU Directive 2011/65/EU limits the use of certain dangerous materials for electric and electronic devices (RoHS conformity).</p> <p>This product does not contain any of the prohibited substances listed in EU Directive 2011/65/EU and does not exceed the maximum authorized concentrations specified. There are currently no equivalent alternative substances for individual electronic components used in our products. We are therefore making use of exemptions 7.a-I, 7.c-I and 6.c (for accessory cables) in Annex III of this Directive. ETAS confirms that the product meets this directive applicable in the European Union.</p>
	<p>KCC conformity</p> <p>With the KC mark attached to the product or its packaging, ETAS confirms that the product has been registered in accordance with the applicable, product-specific KCC guidelines of the Republic of Korea.</p>
	<p>CMIM conformity</p> <p>With the CMIM mark attached to the product or its packaging, ETAS confirms that the product corresponds to the product-specific, applicable directives of the Kingdom of Morocco.</p> <p>The CMIM Declaration of Conformity for the product is available upon request.</p>

Symbol	Description
	<p>UKCA conformity</p> <p>With the UKCA mark attached to the product or its packaging, ETAS confirms that the product meets the applicable, product-specific British standards and directives. The UKCA Declaration of Conformity for the product is available upon request.</p>
<p>CAN ICES / NMB</p> 	<p>CAN ICES conformity</p> <p>This product complies with the Canadian standard:</p> <p>CAN ICES-003(*) / NMB-003(*)</p> <p>* The applicable class of the device is labeled on the product.</p>
	<p>Product return and recycling</p> <p>The European Union (EU) released the Directive for Waste Electrical and Electronic Equipment - WEEE to ensure the setup of systems for collecting, treating and recycling electronic waste in all countries of the EU.</p> <p>This ensures that the devices are recycled in a resource-friendly way that does not represent any risk to personal health and the environment.</p> <p>The WEEE symbol on the product or its packaging identifies that the product may not be disposed of together with the remaining trash.</p> <p>The user is obligated to separately collect old devices and provide them to the WEEE return system for recycling.</p> <p>The WEEE Directive applies to all ETAS devices, but not to external cables or batteries.</p> <p>Additional information about the recycling program of ETAS GmbH is available from www.etas.com/hotlines.</p>

8.4 Connectors

Note

All connections are shown with view of the module interfaces.

8.4.1 Terminal assignment of sockets

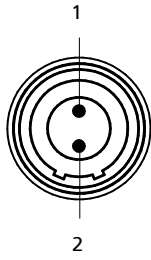
Connection "7-29 V"**Fig. 5-2** Connection "7-29 V"

Pin	Signal	Description
1	UBATT+	Supply voltage, positive
2	Ground	Ground

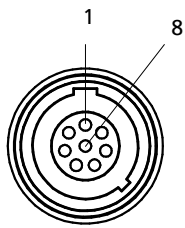
"FE-HOST" connection**Fig. 5-3** "FE-HOST" connection

Pin	Signal	Description
1	-	Reserved
2	-	Reserved
3	-	Reserved
4	RX+	Receiving data, positive
5	TX-	Transmitting data, negative
6	RX-	Receiving data, negative
7	-	Reserved
8	TX+	Transmitting data, positive

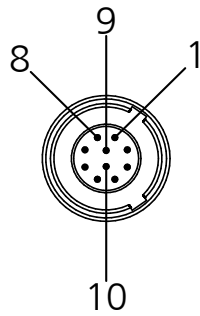
"GE-HOST" connection**Fig. 5-4** "GE-HOST" connection

Pin	Signal	Description
1	BI_DA+	
2	BI_DA-	
3	BI_DB+	
4	BI_DC+	
5	BI_DC-	
6	BI_DB-	
7	BI_DD+	
8	BI_DD-	
9	N.C.	Not connected
10	N.C.	Not connected

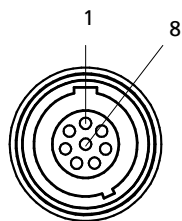
Connections "ETH1" to "ETH6"**Fig. 5-5** Connections "ETH1" to "ETH6"

Pin	Signal	Description
1	UBATT+	Supply voltage, positive
2	UBATT+	Supply voltage, positive
3	UBATT-	Supply voltage, negative

Pin	Signal	Description
4	RX+	Receiving data, positive
5	TX-	Transmitting data, negative
6	RX-	Receiving data, negative
7	UBATT-	Supply voltage, negative
8	TX+	Transmitting data, positive

9 Maintenance

9.1 Cleaning

- Only clean the product when it is de-energized.
- Do not use cleaning agents that could harm the product.
- Do not apply cleaning agents directly onto the product.
- Use a dry or slightly dampened, soft, lint-free cloth.
- Make sure that no moisture enters the product.

9.2 Firmware and software update

9.2.1 Updating the Firmware

The firmware for the product can be updated using the ETAS "Hardware Service Pack" (HSP) service software. You can find the software in the Download Center on the ETAS website: www.etas.com/HSP

9.3 Repair service

If repairs are required, send the product to ETAS.

10 Return form

You can find the return form and information about this process on the ETAS website: www.etas.com/en/support/hw_return_form.php.

11 Accessories and order information

11.1 Module

Order name	Short name	Order number
ES600.2 Synchronization and Power Management Module	ES600.2	F 00K 109 493
ES600.2 Synchronization and Power Management Module with Safety Cable	ES600.2-S	F 00K 110 453

11.2 Cables

11.2.1 Power cables

11.2.1.1 CBP120-2

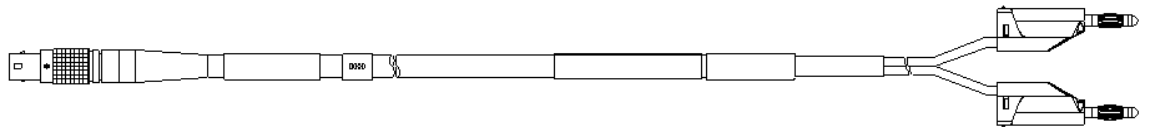

Power supply cable with standard banana plugs

Side A

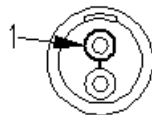

Side B

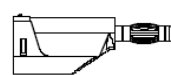

Pin	Signal	Plug	Signal
1	UBATT	red	UBATT
2	Ground	black	Ground

Order name	Short name	Order number
Power Supply Cable, Lemo 1B FGJ Banana (2fc-2mc), 2 m	CBP120-2	F 00K 102 584

11.2.1.2 CBP1205

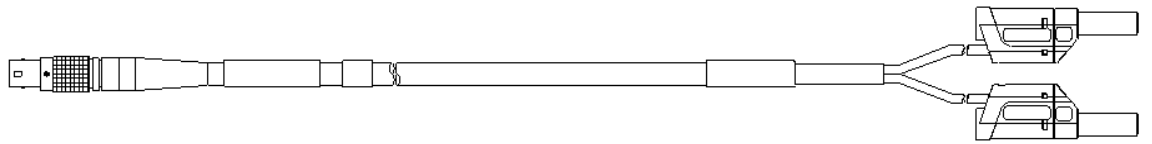

Power supply cable with safety banana plugs

Side A

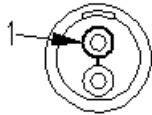

Side B



Pin	Signal	Plug	Signal
1	UBATT	Red	UBATT
2	Ground	Black	Ground

Order name	Short name	Order number
Power Supply Cable, Lemo 1B FGJ – Safety Banana (2fc-2mc), 2 m	CBP1205-2	F 00K 110 023



Note

Power supply cables with safety banana plug are suitable only for connection to voltage sources with safety socket.

11.2.2 Data cables

11.2.2.1 CBE100-3 / CBE100-8



Cable for the "FE-HOST" connection

Order name	Short name	Order number
Ethernet PC Connection Cable, Lemo 1B FGG - RJ45 (8mc-8mc), 3 m	CBE100-3	F 00K 102 559
Ethernet PC Connection Cable, Lemo 1B FGG - RJ45 (8mc-8mc), 8 m	CBE100-8	F 00K 102 571

11.2.2.2 CBE130-0m45 / CBE130-3

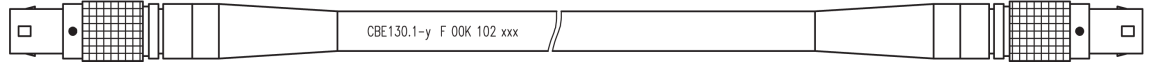

Cable for the connections "ETH1" to "ETH6"

Order name	Short name	Order number
Ethernet Connection and Power Supply Cable, Lemo 1B FGF Lemo 1B FGD (8mc-8mc), 0m45	CBE130-0m45	F 00K 102 748
Ethernet Connection and Power Supply Cable, Lemo 1B FGF Lemo 1B FGD (8mc-8mc), 3 m	CBE130-3	F 00K 102 587

11.2.2.3 CBE140-0m45

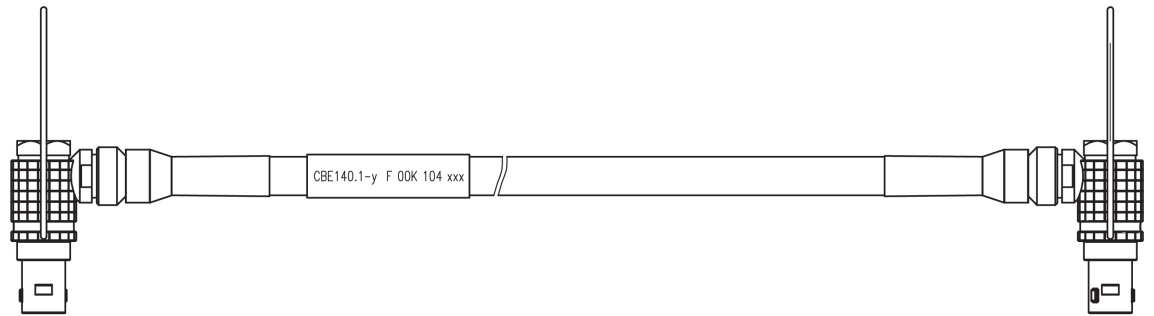

Cable for the connections "ETH1" to "ETH6"

Order name	Short name	Order number
Ethernet Connection and Power Supply Cable, Lemo 1B FGF Lemo 1B FGD (8mc-8mc), 0m45	CBE140-0m45	F 00K 104 153

11.2.2.4 CBE250-3 / CBE250-5 / CBE250-8



Cable for the "GE-HOST" connection

Order name	Short name	Order number
Ethernet PC Connection Cable 1 Gbit/s, Lemo 1B FGM – RJ45 (10fc-8mc), 3 m	CBE250-3	F 00K 109 469
Ethernet PC Connection Cable 1 Gbit/s, Lemo 1B FGM – RJ45 (10fc-8mc), 5 m	CBE250-5	F 00K 109 470
Ethernet PC Connection Cable 1 Gbit/s, Lemo 1B FGM – RJ45 (10fc-8mc), 8 m	CBE250-8	F 00K 109 471

11.2.3 Adapter cables

11.2.3.1 CBAE330-0m5

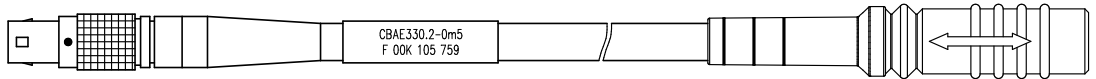

Adapter cable for connecting 1 Gbit/s Ethernet to 100 Mbit/s Ethernet

Order name	Short name	Order number
Ethernet Connection Adapter Cable 1 Gbit/s to 100 Mbit/s, Lemo 1B PHE - Lemo 1B FGF (10fc-8mc), 0m5	CBAE330-0m5	F 00K 105 759

11.3 Other

11.3.1 Housing accessories

Order name	Short name	Order number
T-connector for ES600 housing	ES600_H_TB	F 00K 001 925
Device feet	ES600_H_F	F 00K 001 924

12 Contact information

Technical support

For details of your local sales office as well as your local technical support team and product hotlines, take a look at the ETAS website:

www.etas.com/hotlines

ETAS offers trainings for its products:

www.etas.com/academy



ETAS headquarters

ETAS GmbH

Borsigstraße 24	Phone:	+49 711 3423-0
70469 Stuttgart	Fax:	+49 711 3423-2106
Germany	Internet:	www.etas.com

13 Legal information

13.1 Use of Open Source Software

The product might use Open Source Software (OSS). This software is installed on the product at shipment and does not need to be installed or updated by the user. If OSS is used, see the accompanying "OSS Attributions Document" for more information.

13.2 Certification and conformity

13.2.1 Declarable substances

European Union

Some products from ETAS GmbH (e.g. modules, boards, cables) use components with materials that are subject to declaration in accordance with the REACH regulation (EC) no.1907/2006. The REACH Declaration is available online at www.etas.com/reach and is continuously updated.

13.3 Standards and norms

The ES600.2 complies with the following standards and norms:

Standards	Title	Further information
IEC 61010-1:2010, IEC 61010-1:2012	Safety requirements for electrical equipment for measurement, control, and laboratory use - Part 1: General requirements	
CISPR 11:2009 + A1:2010	Industrial, scientific and medical equipment – Radio-frequency disturbance characteristics – Limits and methods of measurement	Class of the equipment: Class B Group of the equipment: 1

13.3.1 EMC Class B

USA

This equipment has been tested and found to comply with the limits for a Class B digital device, pursuant to part 15 of the FCC Rules. These limits are designed to provide reasonable protection against harmful interference in a residential installation. This equipment generates, uses and can radiate radio frequency energy and, if not installed and used in accordance with the instructions, may cause harmful interference to radio communications. However, there is no guarantee that interference will not occur in a particular installation. If this equipment does cause harmful interference to radio or television reception, which can be determined by turning the equipment off and on, the user is encouraged to try to correct the interference by one or more of the following measures:

- Reorient or relocate the receiving antenna.
- Increase the separation between the equipment and receiver.
- Connect the equipment into an outlet on a circuit different from that to which the receiver is connected.
- Consult the dealer or an experienced radio/TV technician for help.

Responsible Party – U.S. Contact Information

ETAS Inc.
15800 N. Hagerty Road
Plymouth, MI
48170
www.etas.com/US